

NOTES:

1. CABLE: CAT5, STP 26AWG*4P+AE+D.W.
JACKET COLOR: BLACK.
2. TESTING:
 - (1) 100% TEST OPEN, SHORT AND MISWIRE.
 - (2) INSULATION RESISTANCE: 5 MEGAOHMS MIN.
 - (3) CONDUCTOR RESISTANCE: 3 OHMS MAX.
 - (4) HI-POT: 200V DC.
3. SOLDER D.W. ON SHELL OF RJ45 PLUG.
4. RoHS COMPLIANT.
5. Specify Length as Suffix on Part Number in mm.
For Example:
RJ45S-10399-5000 = 5000mm Long RJ45 CAT5 STP Cable.

WIRE LIST

C1	COLOR		C2
1	WHITE/ORANGE	TWISTED	1
2	ORANGE		2
3	WHITE/GREEN	TWISTED	3
6	GREEN		6
4	BLUE	TWISTED	4
5	WHITE/BLUE		5
7	WHITE/BROWN	TWISTED	7
8	BROWN		8
SHELL	DRAIN WIRE		SHELL

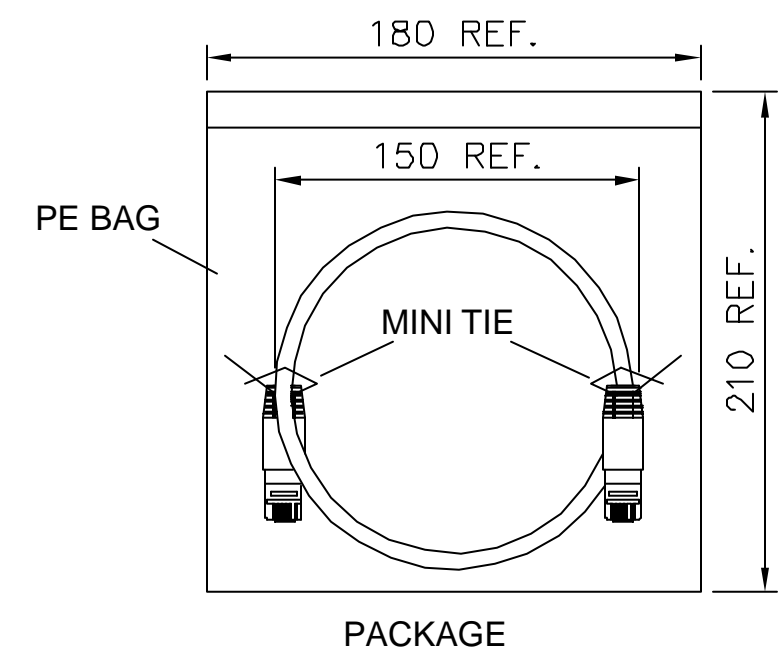

ORDER INFORMATION

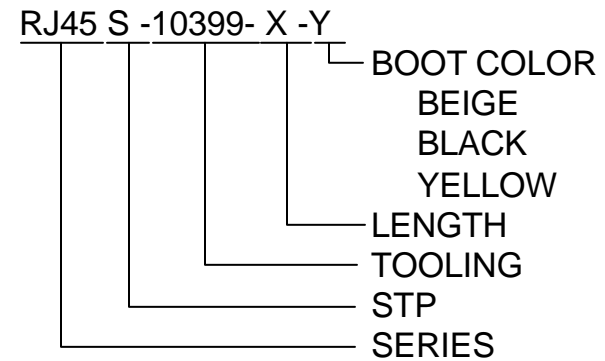

3	CABLE	3M	CAT 5 STP	
2	COVER BOOT	2PCS	45P PVC OPTION	
1	RJ45 8P8C PLUG	2PCS	FULL SHELL G/F	
NO.	DESCRIPTION	Q'TY	MATERIAL	P/N

TOLERANCE	
LINEAR	ANGLES
X.±	X'.±
.X±0.25	.X'±
.XX±0.15	.XX'±
.XXX±0.05	.XXX'±



TITLE: CAT 5 STP CABLE ASSY			
PART NO. RJ45S-10399-X		DWG NO. SC-10399	
UNITS	SCALE	SHEET	REV
MM	NONE	1 OF 1	A

[A]	ISSUED	AXL	1/3/07'
REV	ECN NO.	NAME	DATE

APPD:	MAT'L:
CHKD:	FINISH:
DRWN: AXL	Q'TY:

